

Haltemagnet mit Ankerplatte

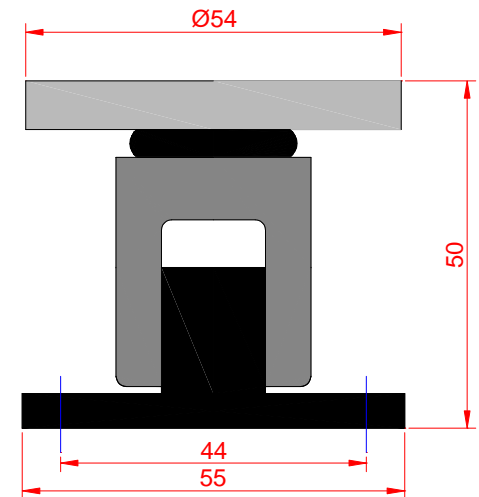
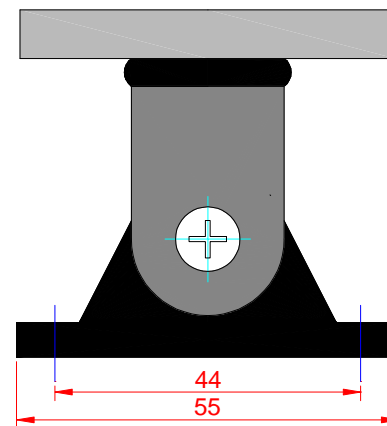

Art.-Nr. 040 239 EV

Set in Einzelverpackung, bestehend aus:

- Elektro-Haftmagnet EM GD 50 mit Unterbrechertaste
24 V DC / 1.6W / 550N / ED: 100%
- Gehäuse Kunststoff weiss

- Winkel-Ankerplatte
Fuss Kunststoff schwarz

- 4 Dübel und 8 Schrauben